

Big Green Egg Table

PROJECT PLAN

YellaWood
Pressure Treated Pine



Create a modern, clean and strong home for your grilling champion.

This custom table is designed to accommodate a medium-sized Big Green Egg[®] to highlight your grilling work-horse and give you extra space for cooking at ease.

It features a shallow, built-in shelf to store grilling utensils, plates and other periphery. The legs are thin planks laid up to maximize their strength while remaining sleek.

You'll start with the construction of the frame, then move on to assembling the shelf and brace supports.

Next, you will lay out surface planks and cut out the circle to fit the Big Green Egg[®]. After some light finishing, you'll be ready to grill in style all summer long.

Make sure to take proper safety precautions, including always wearing gloves, goggles and a dust mask when you're cutting or sanding.

Note: Big Green Egg[®] is a registered trademark of Big Green Egg, Inc.

BUILD TIME

9
HRS

DIFFICULTY



COST



BuildYella.com

Big Green Egg Table

WHAT YOU'LL NEED



CUTLIST

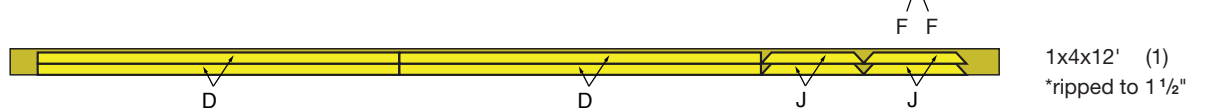
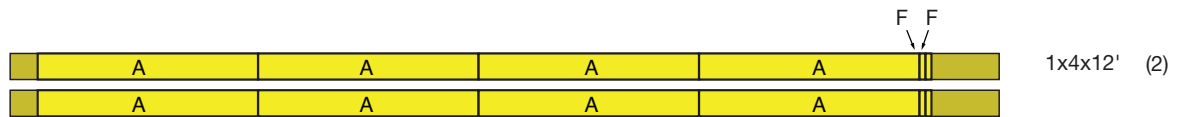
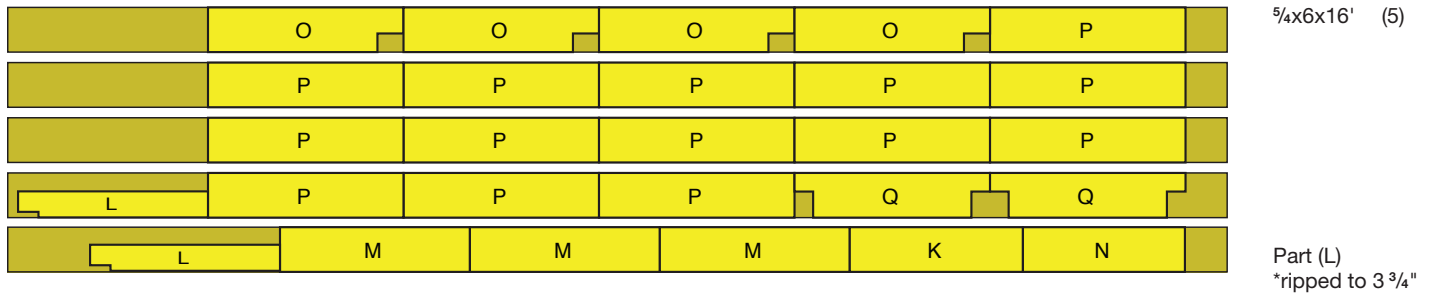

Big Green Egg Table

WHAT YOU'LL NEED

YellaWood
Pressure Treated Pine

SUPPLIES

WOOD STOCK

5x 5/4x6x16'

1x 2x4x6'

3x 1x4x12'

1x 1x4x10'

1x 1x4x6'

Note:

For this project we chose to use YellaWood SuperSelect® brand KDAT products for a clear appearance. To learn more about this product, visit yellawood.com/supersselect

TOOLS



Miter saw
(or hand or circular saw)



Table saw



Drill/driver



Nail gun



Miter square



Jigsaw

HARDWARE

1 LB BOX

1 1/4" Star-drive flat-head decking screws

2" Star-drive flat-head decking screws

~ 30 EACH

18-gauge 1 1/2" nails

18-gauge 1" nails



Clamps



Wood glue



1/8" Countersink
drill bit

OTHER

1x Metal tie plate (16-gauge 3 x 7")

10x #8 1 1/4" Wafer wood screws (for tie plate)

1x 15" x 15" Concrete paver for Big Green Egg
(or 2x 7 1/2" x 15 1/2")



Measuring
tape

BUILD TIME

CUTTING

2
HRS

+

ASSEMBLY

6
HRS

+

FINISHING

1
HRS

=

TOTAL

9
HRS

Big Green Egg Table

RENDERS

YellaWood
Pressure Treated Pine



Big Green Egg Table

DIMENSIONS & DIAGRAMS

Notes:

All measurements are approximate.

Cut stock in the correct sequence of steps because many dimensions are directly measured and will vary based on actual stock and construction.

Board dimensions can vary, so be sure to **measure your stock**.

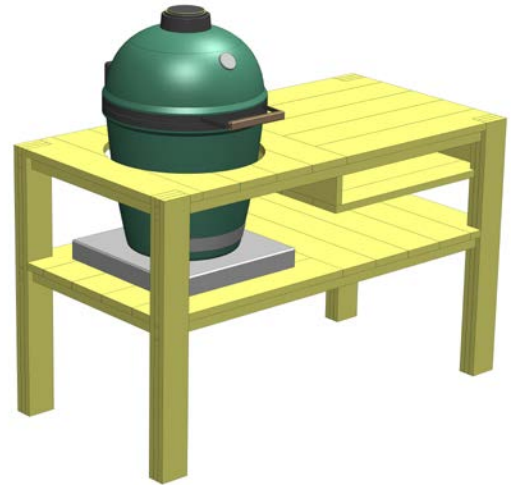

TOP

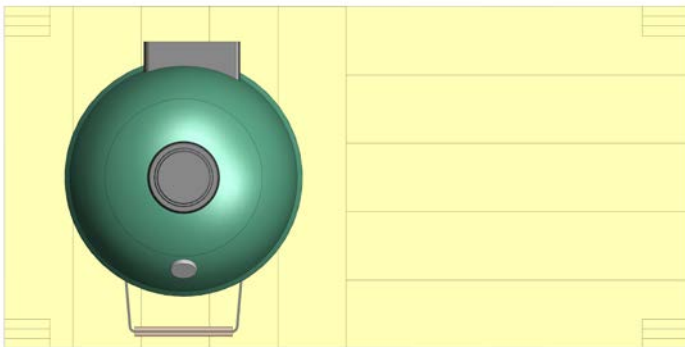

FRONT

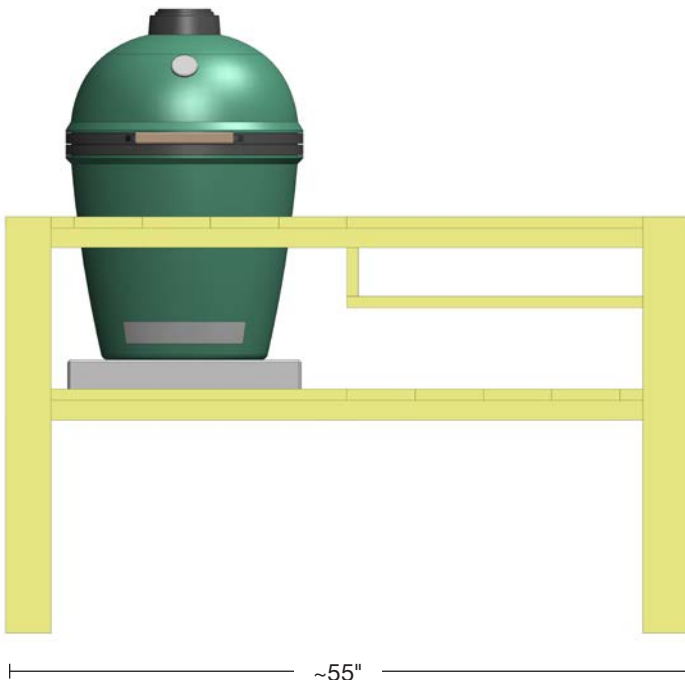

~55"

LEFT SIDE

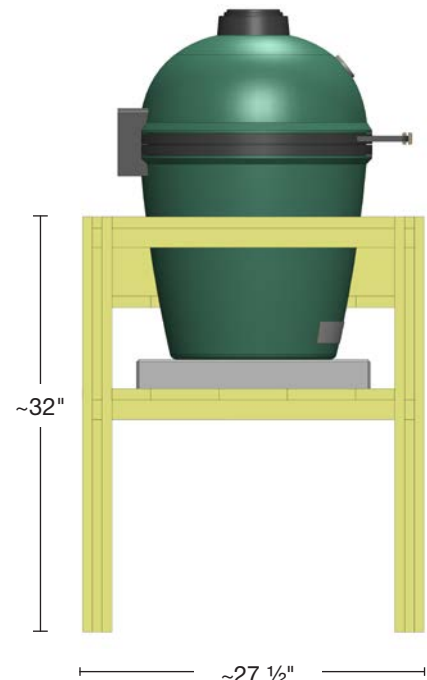

~32"

~27 1/2"

Big Green Egg Table

OVERVIEW OF STEPS

YellaWood
Pressure Treated Pine

1: LEFT & RIGHT LEG STRUCTURES



2: LEG SUPPORTS



3: BRACE SUPPORTS



4: SHELF

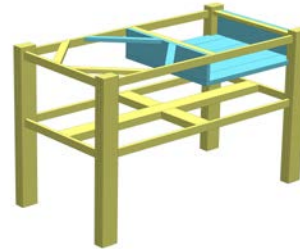

5: LOWER PLANKS

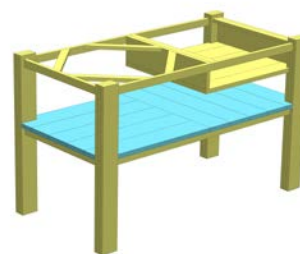

6: UPPER PLANKS

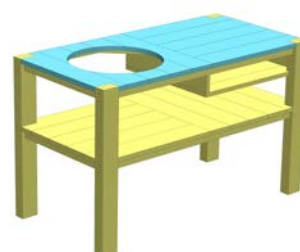

FINAL STEPS: FINISHING & INSTALLING BIG GREEN EGG

Big Green Egg Table

DIMENSIONS & DIAGRAMS

YellaWood
Pressure Treated Pine

STEP 1: LEFT & RIGHT LEG STRUCTURES



CUTLIST

1x4 STOCK

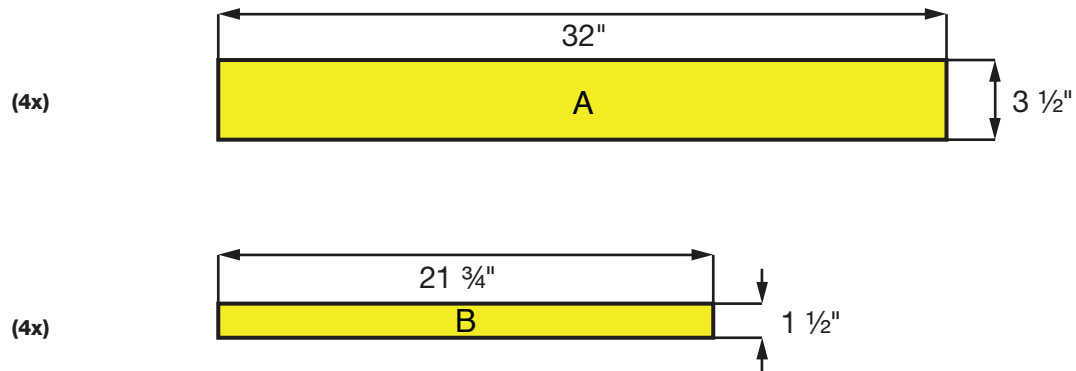

Cuts: For each step, you can pre-cross-cut all of the pieces listed in the Cutlist for each section.

Big Green Egg Table

DIMENSIONS & DIAGRAMS

ASSEMBLY VIEW LEFT & RIGHT LEG STRUCTURES

LEFT

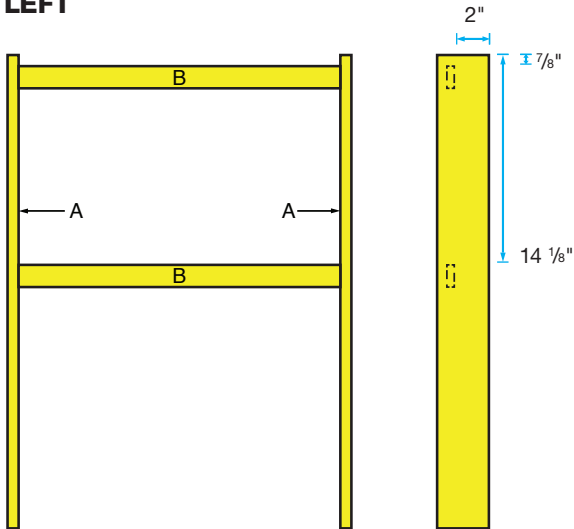

LEFT

FRONT

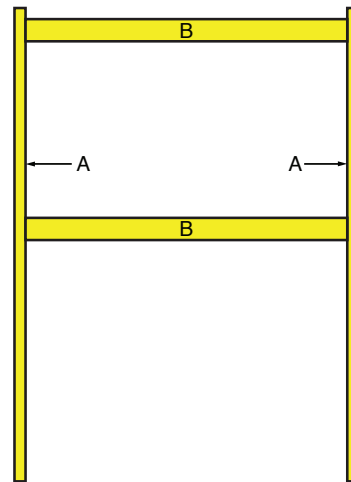

RIGHT

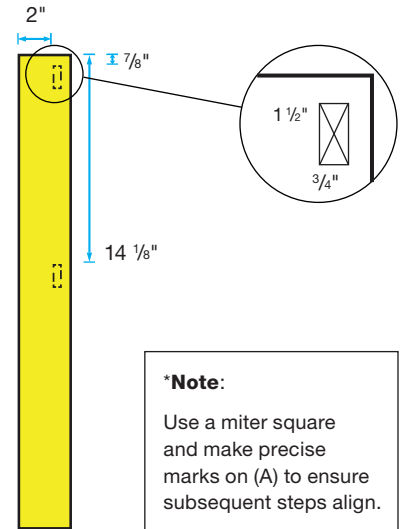

BACK

***Note:**

Use a miter square and make precise marks on (A) to ensure subsequent steps align.

After you have the corner points, draw a rectangle with an "X" in the middle so that you have an intersection location for the counter-sink + screw.

RIGHT

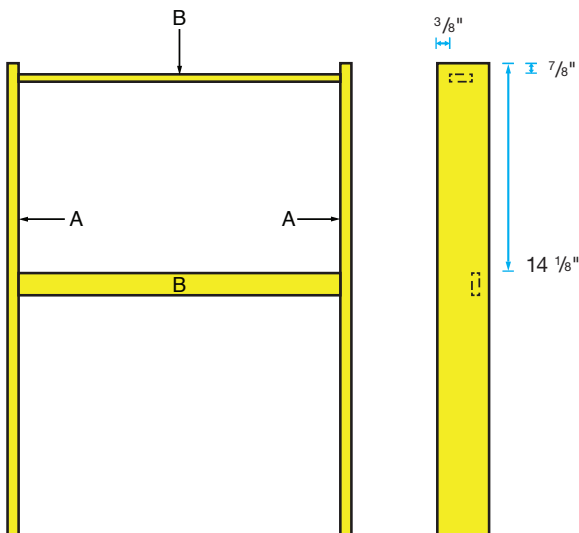

LEFT

FRONT

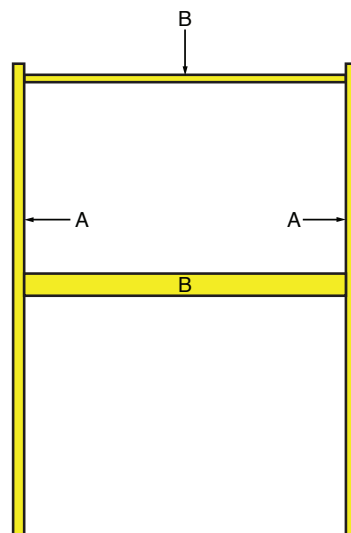

RIGHT

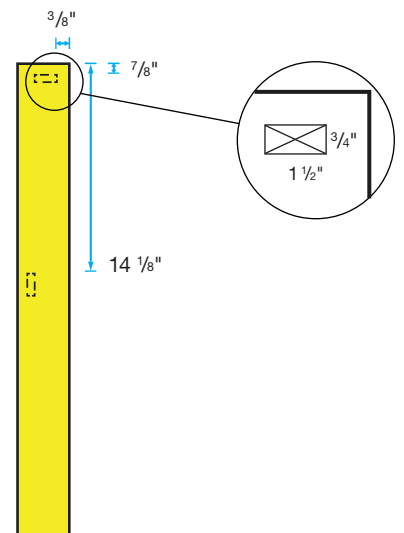

BACK

Big Green Egg Table

BUILDING

YellaWood
Pressure Treated Pine

STEP 1: LEFT & RIGHT LEG STRUCTURES

A: Left Leg Assembly

A1



Cross-cut four 1x4s to a length of 32". These will create parts (A). Then, cross-cut two 1x4s to a length of 21 3/4" for the first part of creating parts (B).

A2

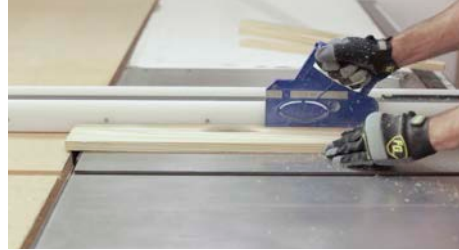

Take the two (B)s and rip them to a width of 1 1/2" - you will be able to get two pieces from each. This will make four total part (B)s.

A3



To mark on part (A) where to attach part (B), measure 7/8" from the top and 2" from the right edge. This is where the top right corner of part (B) will be placed. Use the corner marks to draw a rectangle.

A4



Make a mark 14 1/8" from the top and 2" from the right edge. This is where the top right corner of another part (B) will be positioned. Draw a rectangle here as well.

A5



Flip (A) over and inscribe the same 2 rectangles on the opposite side in a mirrored fashion. Having these marks on the other side of the board will indicate where to pin and screw (B) to (A).

A6



Place a piece of 5/4 board on your work surface to support part (B), and prop (A) vertically. Use clamps to secure (A) to the top of the scrap piece and to the table.

A7



Glue edge of (B) and pin in place using a nail gun and two 18-gauge nails.

A8



Next, drill a pilot hole in the center of the rectangle you drew. Use one 2" screw each to secure the two part (B)s to part (A).

A9



Repeat the rectangle guides on the other part (A). **Note:** the dimensions are the same, just mirrored from left to right.

Tip: Need help, or have questions about how to cut these parts? Watch the video!

Get more project plans at BuildYella.com

Big Green Egg Table

BUILDING

YellaWood
Pressure Treated Pine

STEP 1: LEFT & RIGHT LEG STRUCTURES

A: Left Leg Assembly

A10



Glue, pin with nail gun, drill a pilot hole, and secure (B) with one 2" screw in the center of the rectangle.

A11



Flip assembly over to allow the other (A) to be propped vertically. Attach the 2 (B) parts to this leg in the same way they were attached to first (A). This completes the Left Leg Assembly.

Big Green Egg Table

DIMENSIONS & DIAGRAMS

YellaWood
Pressure Treated Pine

STEP 2: LEG SUPPORTS

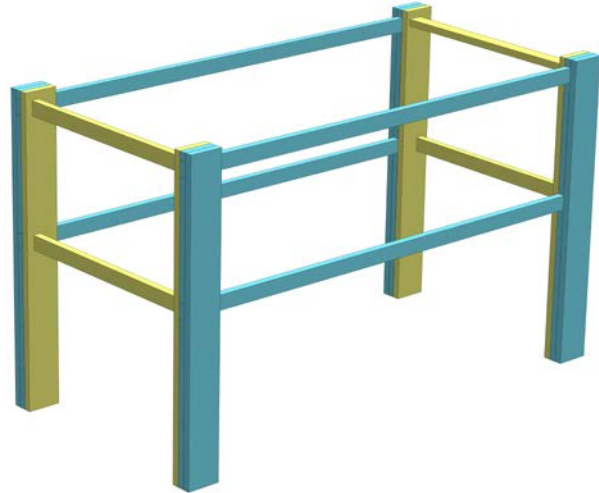

CUTLIST

1x4 STOCK

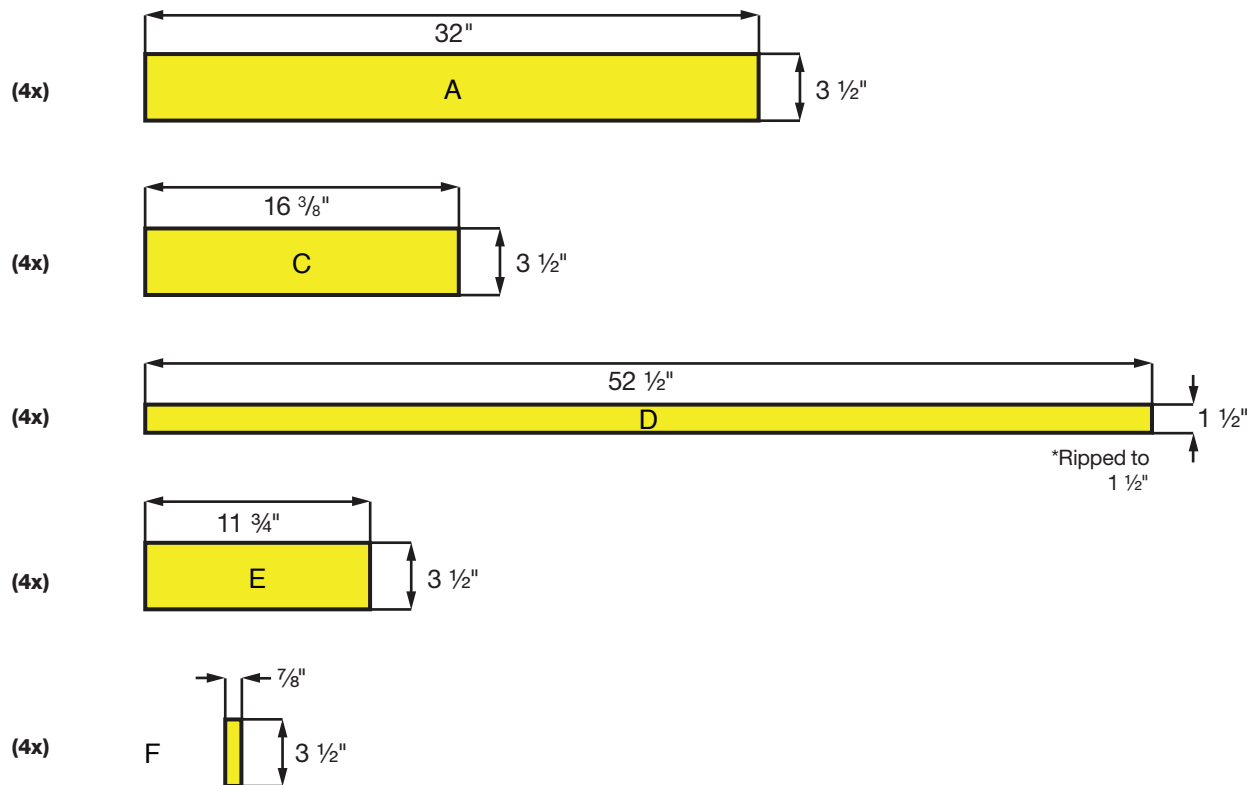

Big Green Egg Table

DIMENSIONS & DIAGRAMS

YellaWood
Pressure Treated Pine

ASSEMBLY VIEW LEG SUPPORTS

LEFT

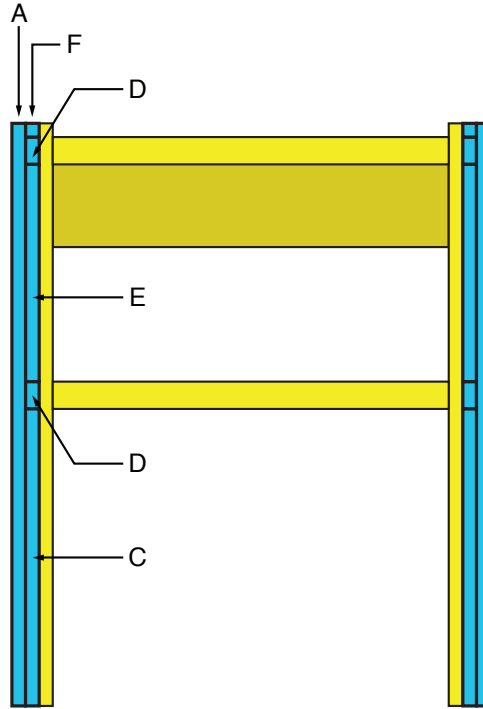

FRONT

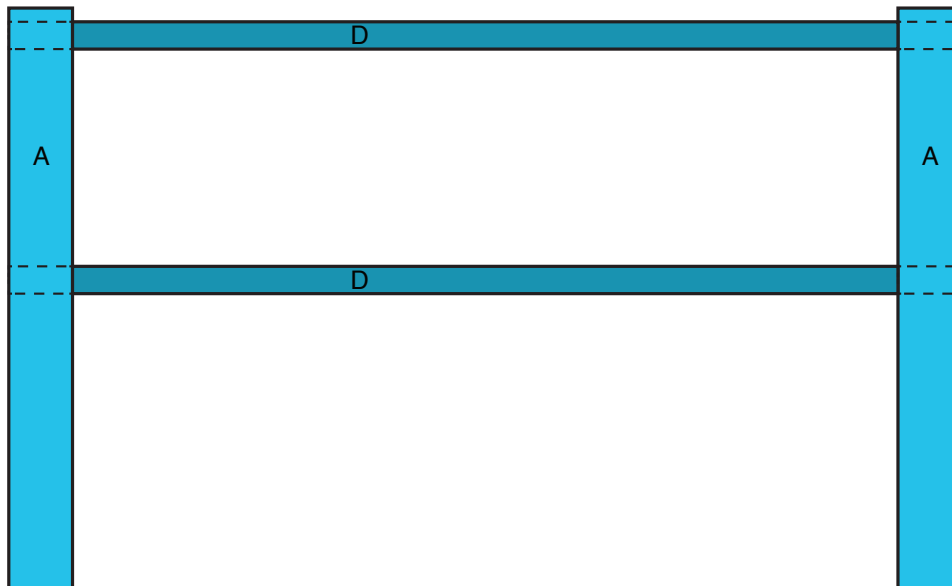

Big Green Egg Table

BUILDING

STEP 2: LEG SUPPORTS

A: Front and Rear Leg Assemblies

A1



For the front and back leg pieces, you'll make four more part (A)s. Cross-cut 1x4s to 32" in length.

A2

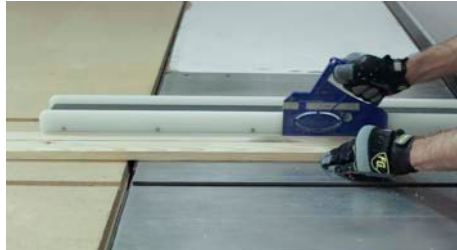

Cross-cut four 1x4s to a length of 16 ³/₈". This will create part (C). For (D)s, cross-cut two 1x4s to a length of 52 ¹/₂", and rip them to 1 ¹/₂" for four total boards.

A3



Cross-cut a 1x4 to a length of 11 ³/₄" to create part (E). You'll need four of these. Then cross-cut a 1x4 to a length of ⁷/₈" to create part (F). You'll need four of these.

A4



To dry-fit all pieces, place part (A) flat on a work surface. Lay part (C) on top of part (A), keeping the bottom edges flush.

A5



Next, lay part (D) on top of part (A), followed by part (E), another part (D), and part (F) at the top. Before fastening (C), ensure it is flush with (A). If not, adjust (C) so it fits.

A6



Use wood glue and 1" nails in a nail gun to pin in place, beginning with part (F). Glue and nails are enough to fasten this section.

A7



Repeat steps A4 - A6 for the other leg assembly.

A8



This completes the Front and Rear Leg Assemblies.

Big Green Egg Table

BUILDING

YellaWood
Pressure Treated Pine

STEP 2: LEG SUPPORTS

B: Combine the Leg Components

B1



Take the front leg components and lay them flat on the work surface. Make sure part (A) is facing down. Take the Left Leg Assembly and place it on top of the Front Leg Assembly.

B2



Apply glue to the assemblies, pin in place with the nail gun using 1 1/2" nails, then drill pilot holes and attach with 2" screws.

B3



Repeat this process on the right side using the Right Leg Assembly.

B4

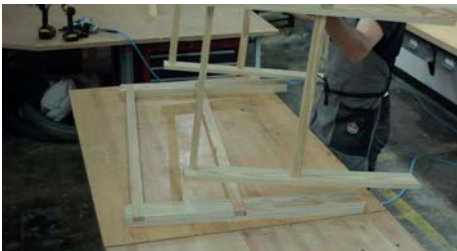

Next, flip the assembly and do the same steps on the other side and place it on top of the other leg assembly.

Big Green Egg Table

DIMENSIONS & DIAGRAMS

STEP 3: BRACE SUPPORTS

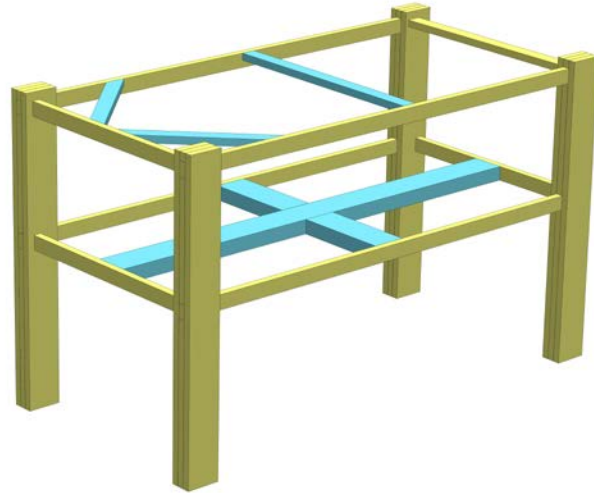

CUTLIST

2x4 STOCK

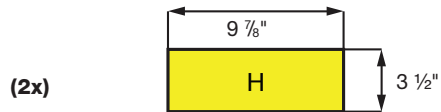
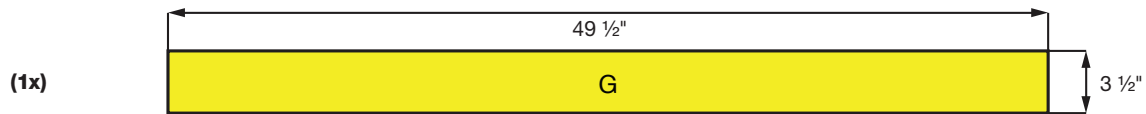

1x4 STOCK

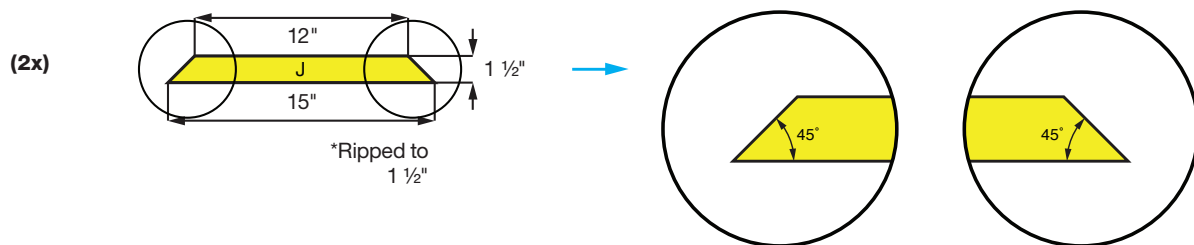
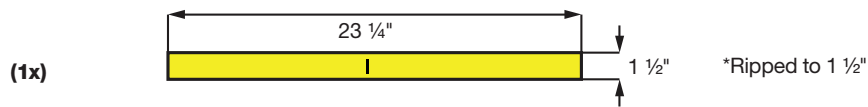

Big Green Egg Table

DIMENSIONS & DIAGRAMS

YellaWood
Pressure Treated Pine

ASSEMBLY VIEW BRACE SUPPORTS

TOP

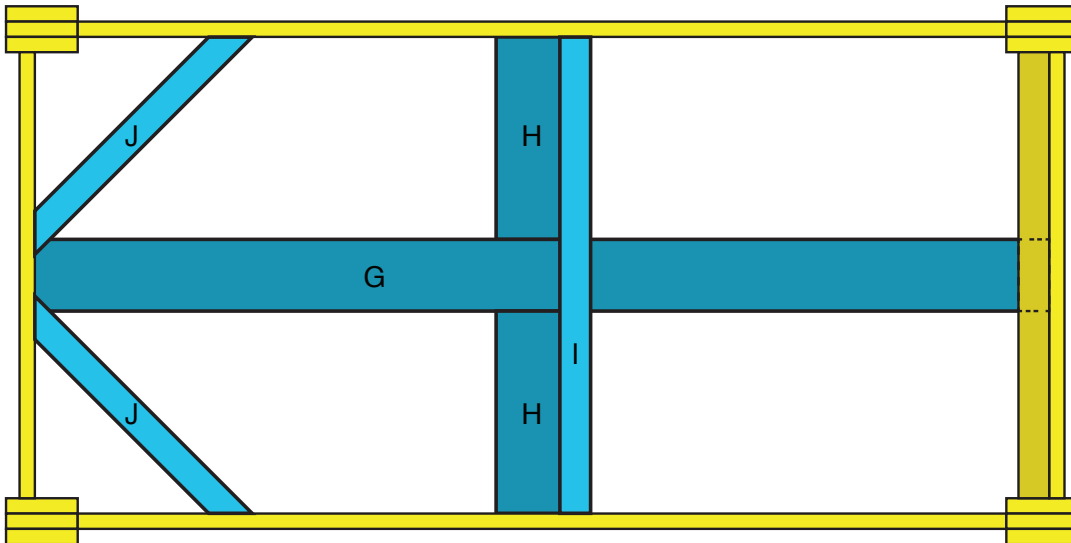

BOTTOM

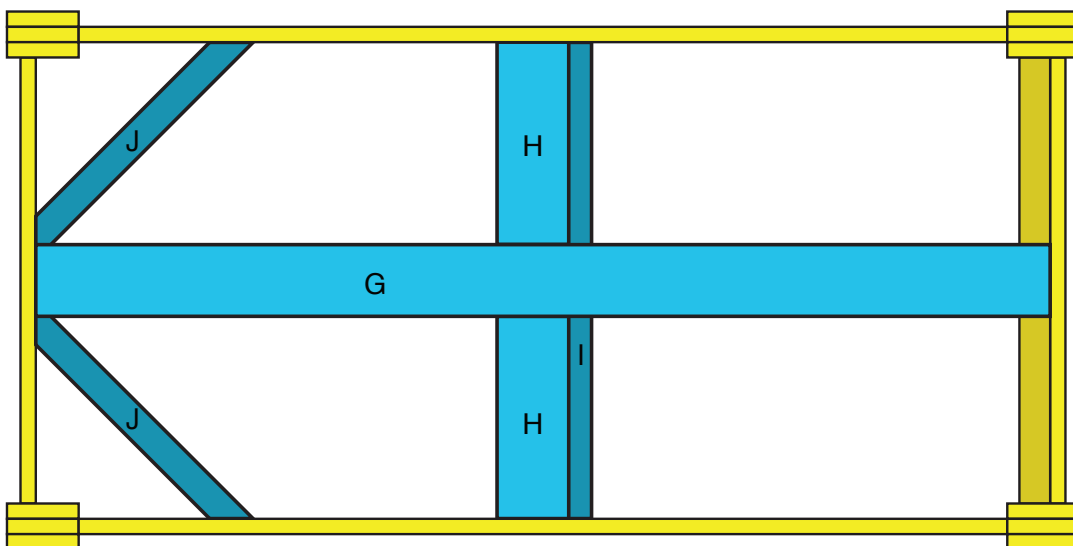

Big Green Egg Table

BUILDING

STEP 3: BRACE SUPPORTS

A: Lower Bracing

A1



Flip assembly 90° and place it on a level surface.

A2



Cross-cut a 2x4 to a length of 49 1/2". This will create part (G). Cross-cut two 2x4s to a length of 9 7/8" to create 2 part (H)s.

A3



Use 1x4 stock to cut part (I) and 2 (J)s. (J)s edges are mitered at 45°.

A4



Now, center parts (H) to bisect (G) as shown.

A5



Use a metal plate tie to connect the three pieces. Place it so most of the holes fall on solid wood and not at joints. Use #8 1 1/4" screws to secure plate to wood.

A6



Take the cross piece assembly and align it on the table frame so it is flush with (D). Use a clamp to hold the (H) edges in place.

A7



Attach (G) edges with two 2 1/2" screws.

A8



After (G) is secure, attach (H)s. This completes the Lower Bracing.

Big Green Egg Table

BUILDING

YellaWood
Pressure Treated Pine

STEP 3: BRACE SUPPORTS

B: Upper Bracing

B1



Cross-cut a piece of 1x4 to a length of 23 1/4", and rip it to a width of 1 1/2" to create part (I).

B2



On the upper part (D) that is on the back side, make a mark 23 1/8" from the left edge. This is where the left edge of part (I) will be positioned.

B3



Glue the edges, pin with 1" nails, drill a pilot hole, and attach part (I) to part (D) with one 2" screw. Repeat on the other side of the assembly.

B4



Position part (J) in the corner between parts (D) and (B). Apply glue, pin with 1" nails, drill a pilot hole, and secure with a 1 1/4" screw at each intersection.

B5



Repeat with the other part (J).

Big Green Egg Table

DIMENSIONS & DIAGRAMS

YellaWood
Pressure Treated Pine

STEP 4: SHELF

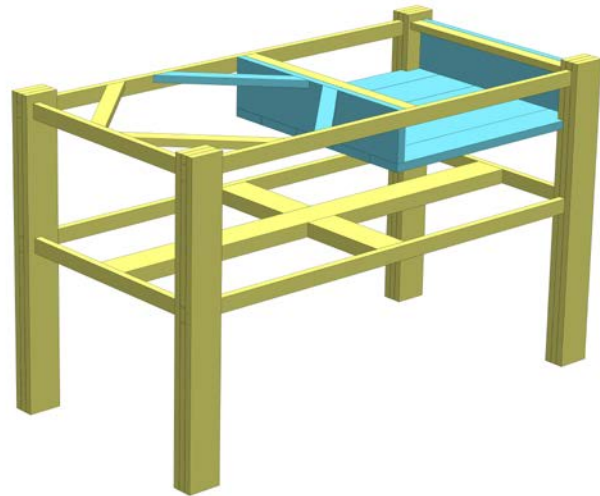

CUTLIST

5/4x6 STOCK

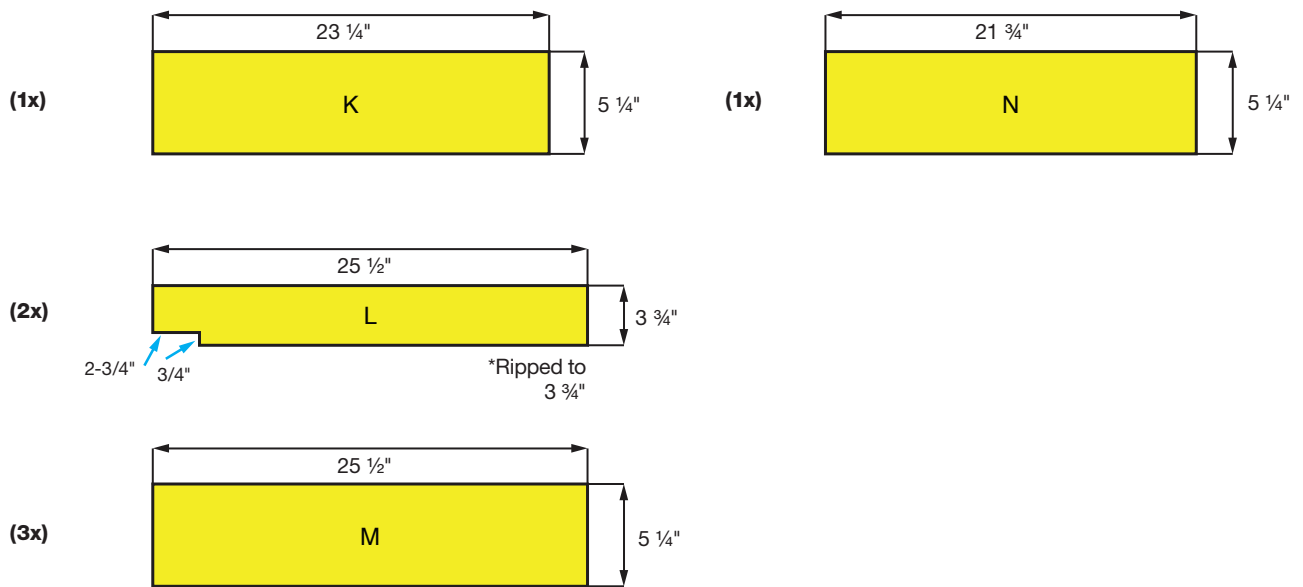

1x4 STOCK

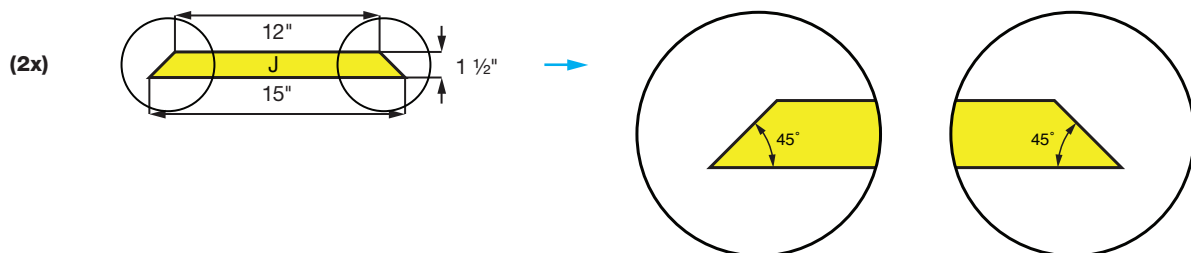

Big Green Egg Table

DIMENSIONS & DIAGRAMS

YellaWood
Pressure Treated Pine

ASSEMBLY VIEW SHELF

TOP

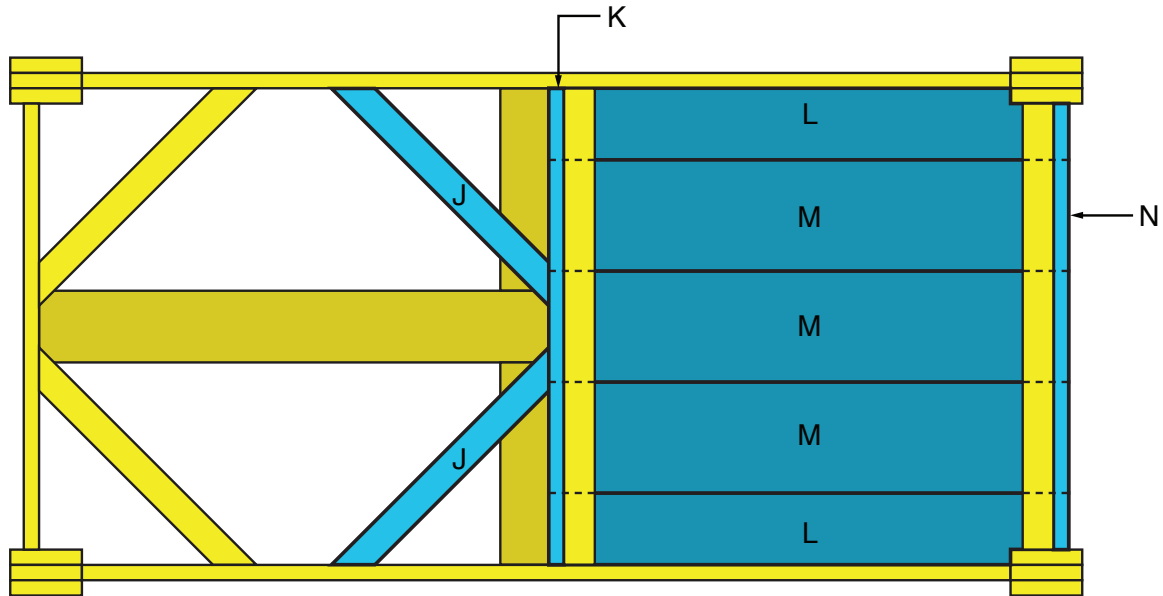

FRONT

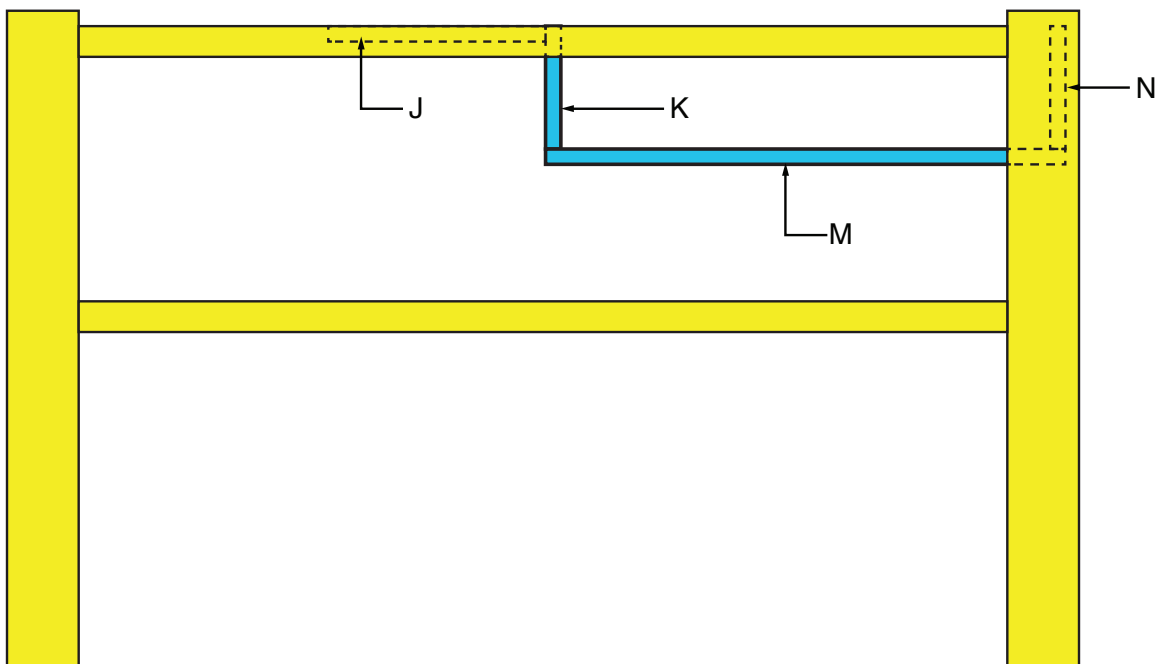

Big Green Egg Table

BUILDING

STEP 4: SHELF

A: Attach to Structure

A1



Cross-cut a $\frac{5}{4} \times 6$ to a length of $23 \frac{1}{4}$ " to make part (K). Then cross-cut two $\frac{5}{4} \times 6$ boards to a length of $25 \frac{1}{2}$ ", and rip them to a width of $3 \frac{3}{4}$ " for two part (L)s.

A2



Make two more (J)s that are 15" long and mitered at 45° .

A3



Make a notch in one corner of each that is $2 \frac{3}{4}$ " by $\frac{3}{4}$ ". This will create two part (L)s.

A4



Cut three $\frac{5}{4} \times 6$ s to a length of $25 \frac{1}{2}$ " - this will create parts (M). Cut a $\frac{5}{4} \times 6$ to a length of $21 \frac{3}{4}$ " to make part (N).

A5



Create the shelf assembly on its own, built upside down. Stand parts (K) and (N) on edge and place them about $23 \frac{3}{4}$ " apart, and dry-fit parts (L) and (M) on top. The two parts (L) should be at the edges.

A6



Glue, nail in place, drill pilot holes, and attach with $1 \frac{1}{2}$ " screws.

A7



Flip the shelf assembly and wipe any excess glue from the inside of the shelf. Then slide it up into place in the leg assembly. The top edges should be flush with the top edges of parts (B) and (I).

A8



Drill pilot holes and attach with $1 \frac{1}{4}$ " screws.

A9



Position part (J) in the corner between parts (D) and (K). Drill pilot holes and attach using $1 \frac{1}{4}$ " screws. Repeat with the other part (J).

Big Green Egg Table

DIMENSIONS & DIAGRAMS

YellaWood
Pressure Treated Pine

STEP 5: LOWER PLANKS

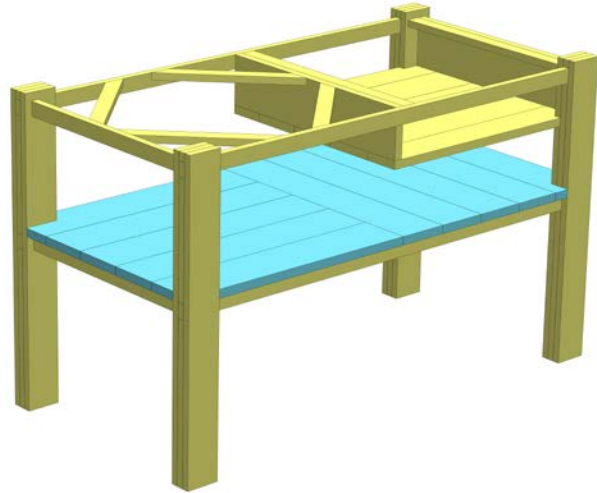

CUTLIST

5/4x6 STOCK

(2x)

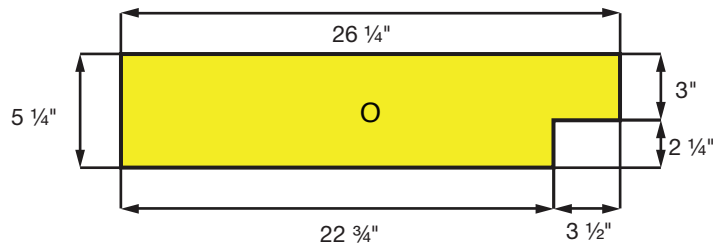

(7x)

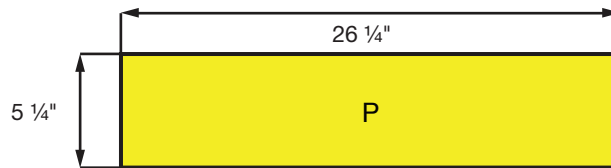

(1x)

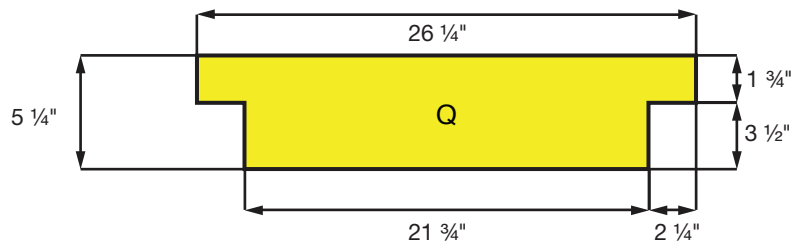

Big Green Egg Table

DIMENSIONS & DIAGRAMS

YellaWood
Pressure Treated Pine

ASSEMBLY VIEW LOWER PLANKS

TOP

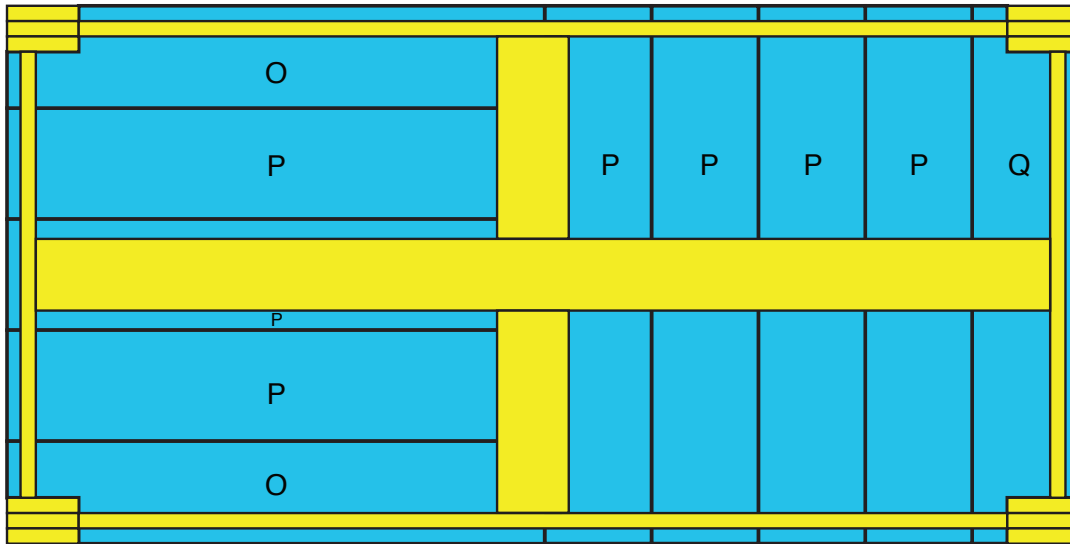

FRONT

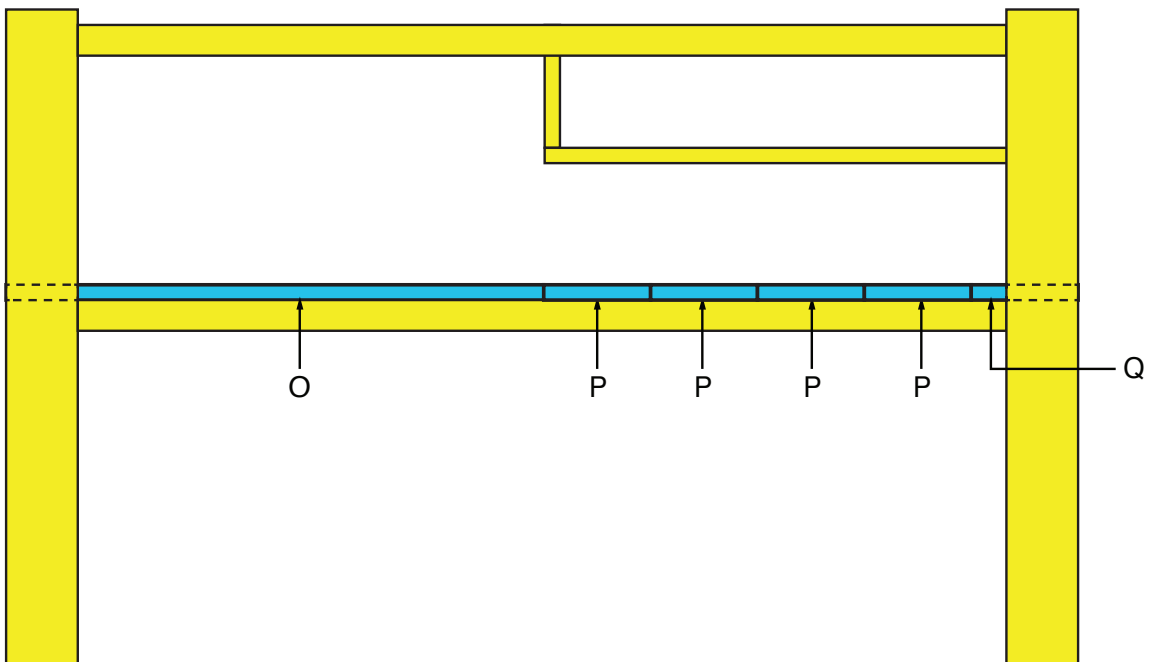

Big Green Egg Table

BUILDING

STEP 5: LOWER PLANKS

A: Left & Right Half

A1



Cross-cut a $\frac{5}{4} \times 6$ to a length of $26 \frac{1}{4}$ " to create part (P). You'll need seven of these in total.

A2



To make part (O), cross-cut four $\frac{5}{4} \times 6$ s to a length of $26 \frac{1}{4}$ ". Using a jigsaw, make a notch in one corner of each board that is $3 \frac{1}{2}$ " by $2 \frac{1}{4}$ ".

A3



Finally, cross-cut two $\frac{5}{4} \times 6$ s to a length of $26 \frac{1}{4}$ ". Make notches in two corners that are $2 \frac{1}{4}$ " by $3 \frac{1}{2}$ ". This will create part (Q).

A4



We'll start with the back left corner of the lower decking. Place part (O) on top of the bracing. The notch should fit around the leg assembly. Dry-fit all planks before attaching.

A5



Pin in place, beginning at corners, with $1 \frac{1}{4}$ " nails to prevent shifting. Nailing is sufficient for this shelf, but if you desire, you can pre-drill and screw in 2" hardware as well.

A6



For the right half, start at the right edge of the table with part (Q). Either nail or drill pilot holes and secure with $1 \frac{1}{4}$ " screws into the bracing. This completes the Lower Planks.

Big Green Egg Table

DIMENSIONS & DIAGRAMS

YellaWood
Pressure Treated Pine

STEP 6: UPPER PLANKS

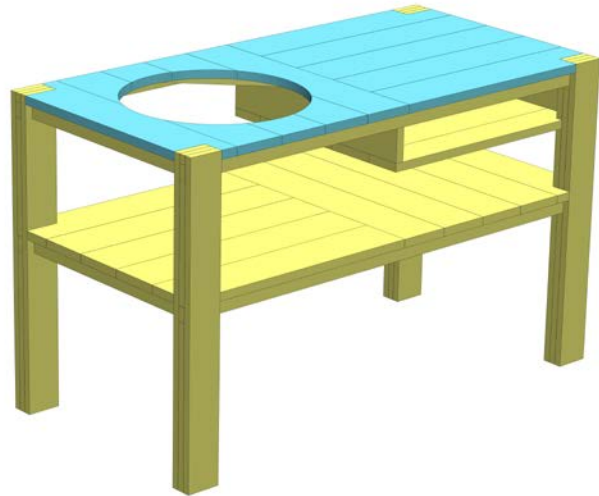

CUTLIST

5/4x6 STOCK

(2x)

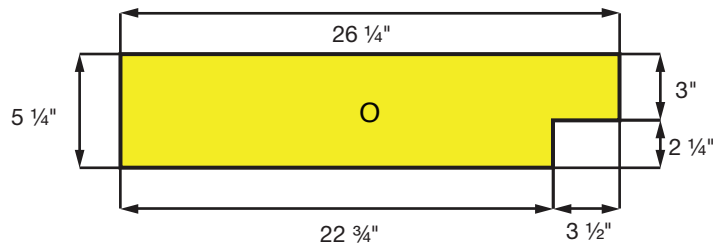

(7x)

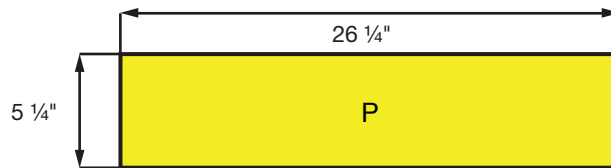

(1x)

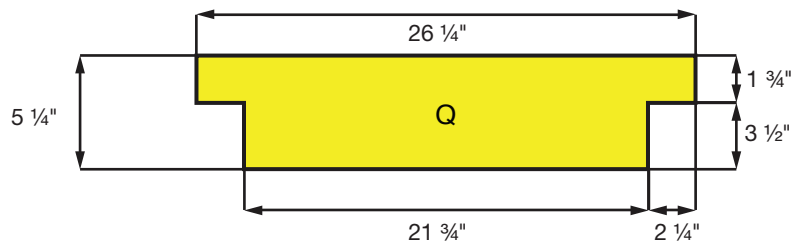

Big Green Egg Table

DIMENSIONS & DIAGRAMS



ASSEMBLY VIEW UPPER PLANKS

TOP

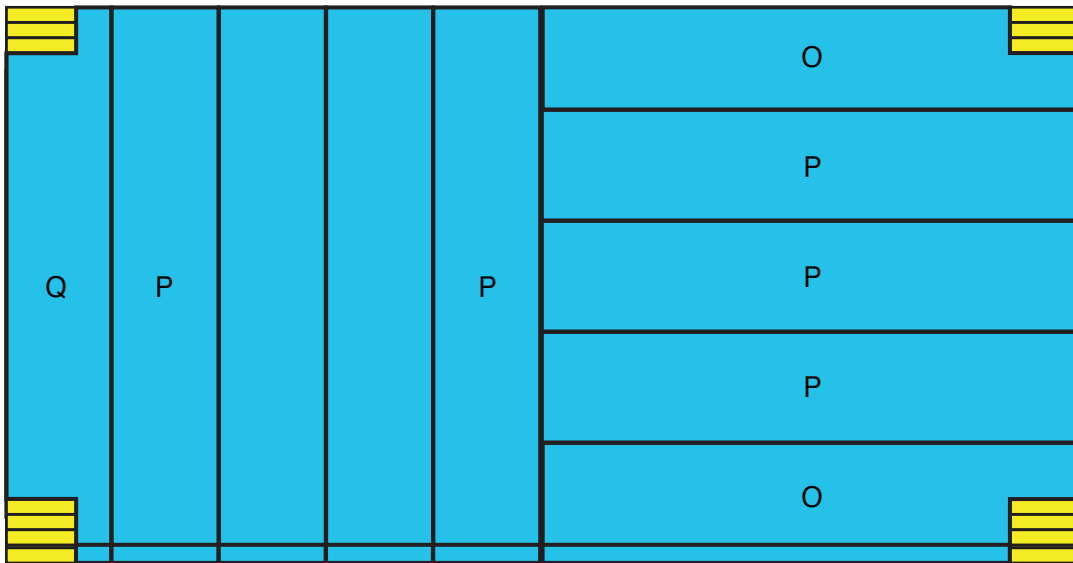

FRONT

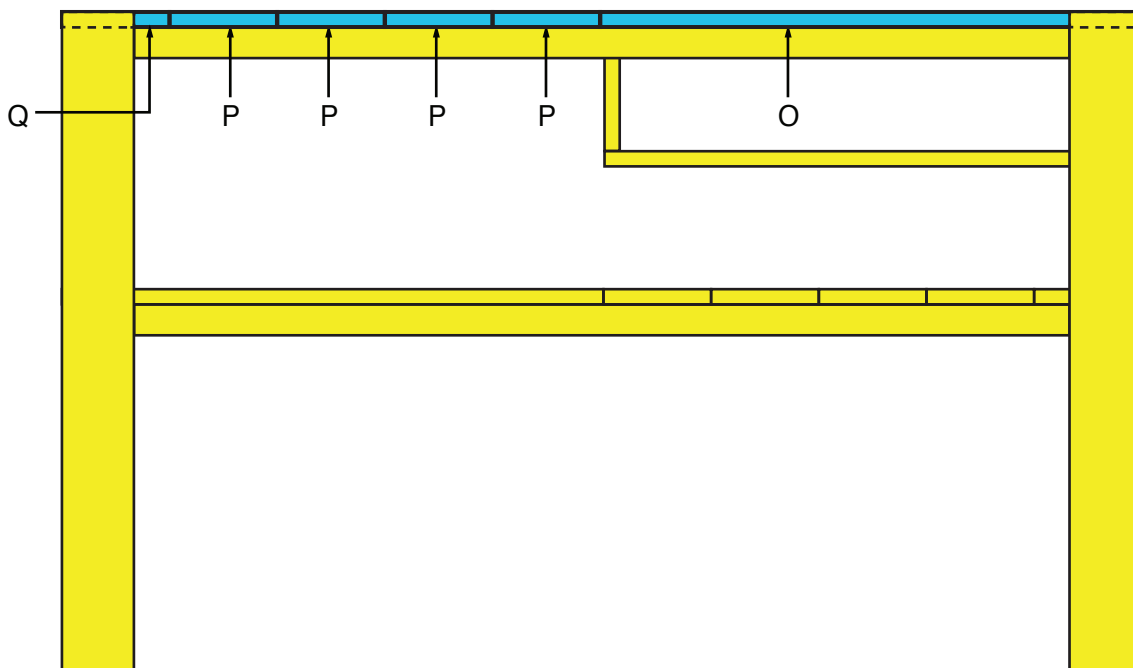

Big Green Egg Table

DIMENSIONS & DIAGRAMS

ASSEMBLY VIEW UPPER PLANKS

TOP

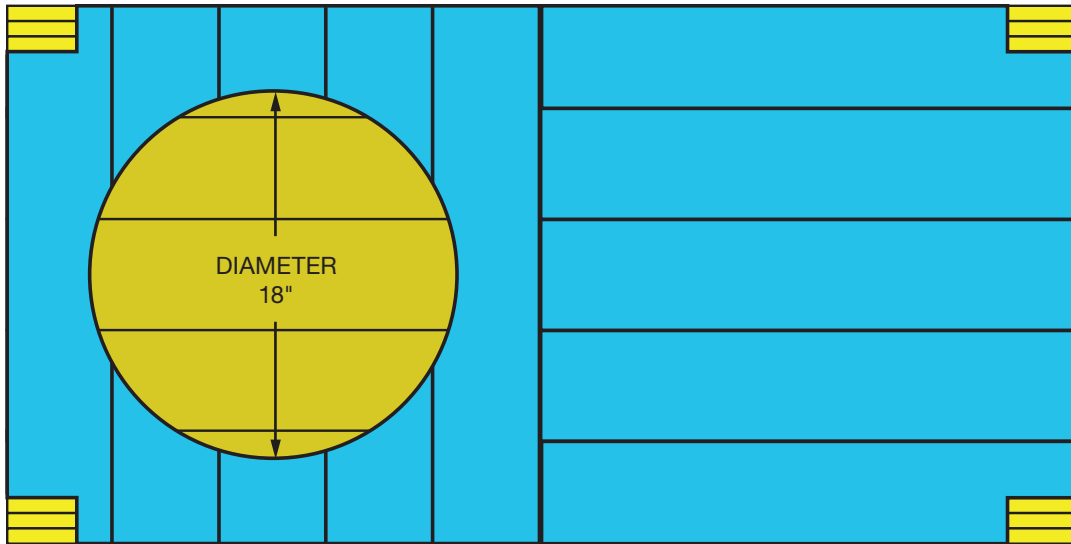

Note: This is the diameter specified by Big Green Egg for the 15"-wide Medium-sized Egg.

Big Green Egg Table

BUILDING

YellaWood
Pressure Treated Pine

STEP 6: UPPER PLANKS

A: Left & Right Half

A1



Cross-cut parts (O), (P), and (Q), for a total of 10 parts.

A2



Starting with the left edge, place part (Q) and four (P)s on the top of the bracing. Dry-fit all planks before attaching.

A3



Use a nail every few inches to pin down the planks, beginning with the corners (Q) and (P). Mark where screws will go, and drill pilot holes before securing planks to the bracing using 1 1/4" screws.

Big Green Egg Table

BUILDING

YellaWood
Pressure Treated Pine

STEP 6: UPPER PLANKS

B: Grill Cutout

B1



The final step is to cut out a circle in the upper decking. Make a mark $13 \frac{3}{4}$ " from the left edge and $13 \frac{1}{8}$ " from the back edge. This will be the center of your circle.

B2



Use a compass* to draw the 18" diameter circle.

B3



With a jigsaw, cut out the circle.

***Making a compass:**

Take a thin piece of scrap wood that's at least 10" long, and make 2 holes whose center points are 9" apart. Put a screw in one hole and place at the center mark.

Put a pencil in the other hole, and, using the screw as a pinpoint, pivot the radius arm to form a circle.

Big Green Egg Table

DIMENSIONS & DIAGRAMS

YellaWood®
Pressure Treated Pine

OPTIONAL: FINISHING

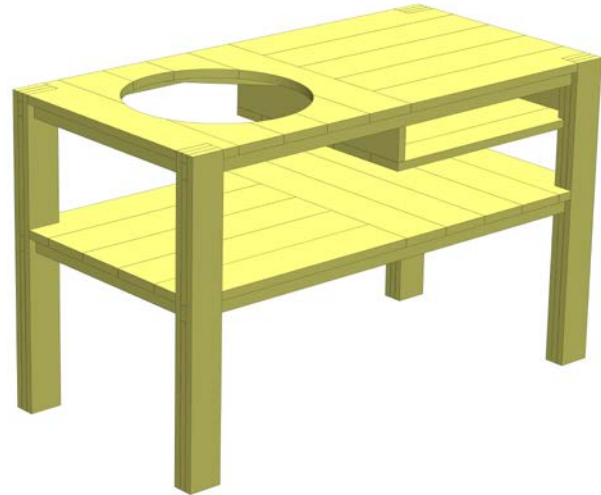

YellaWood® brand products provide the best available pressure treated lumber protection against rot, fungal decay and termites. Sanding edges is recommended to reduce snags and splintering. At a minimum, we recommend annual application of a water repellent. You can also paint or stain it if you prefer.

A1



Ease any sharp edges with a medium grit sanding block. Apply preferred finish to the wood.

Big Green Egg Table

DIMENSIONS & DIAGRAMS

YellaWood
Pressure Treated Pine

INSTALLING BIG GREEN EGG

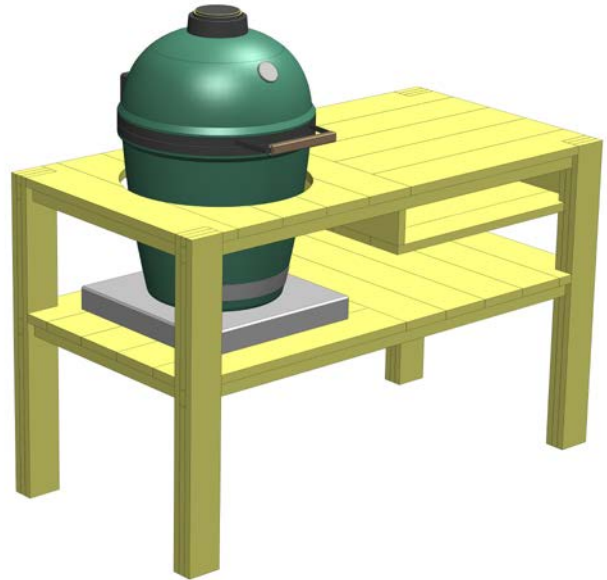

A1



First, place the concrete paver on the lower decking under the circle you cut out.

A2



With the help of a friend or two, lift the Big Green Egg® over the cutout and carefully lower onto the paver.

CONGRATULATIONS. ENJOY YOUR BEAUTIFUL NEW GRILLING STATION!

Big Green Egg Table

GALLERY

YellaWood
Pressure Treated Pine



Big Green Egg Table

FASTENER & HARDWARE INFORMATION



FOR INTERIOR OR EXTERIOR APPLICATIONS

Use fasteners and hardware that are in compliance with the manufacturer's recommendations and the building codes for their intended use. As with any good design and construction practices, treated wood should not be used in applications where trapped moisture or water can occur. Where design and/or actual conditions allow for constant, repetitive or long periods of wet conditions, only stainless steel fasteners should be used.

FOR EXTERIOR APPLICATIONS

The following minimum galvanization levels may be used for connectors, joist hangers, fasteners and other hardware that are placed in direct contact with exterior applications of micronized copper treated wood:

- **Fasteners** – nails, screws, etc. ASTM – A 153 (1 oz/ft²)
- **Hardware** – connectors, joist hangers, etc. ASTM – A 653 G90 (0.90 oz/ft²)

The effects of other building materials within a given assembly, along with environmental factors, should also be considered when selecting the appropriate hardware and fasteners to use for a given project containing treated wood.

Stainless Steel fasteners and hardware are required for Permanent Wood Foundations below grade and are recommended for use with treated wood in other severe exterior applications such as swimming pools, salt water exposure, etc. Type 304 and 316 are recommended grades to use.

ALUMINUM

Aluminum building products may be placed in direct contact with YellaWood® brand products used for interior uses and above ground exterior applications such as decks, fencing, and landscaping projects. Examples of aluminum products include siding, roofing, gutters, door and window trim, flashing, nails, fasteners and other hardware connectors. However, direct contact of treated products and aluminum building products should be limited to code-compliant construction applications that provide proper water drainage and do not allow the wood to be exposed to standing water or water immersion.

We recommend you contact the aluminum building products manufacturer for its recommendations regarding use of its aluminum products in contact with treated wood in ground contact applications or when exposed to salt water, brackish water, or chlorinated water, such as swimming pools or hot tubs.

Also check with the aluminum building products manufacturer regarding compatibility with other chemicals and cleaning agents and the use of their aluminum products in commercial, industrial, and specialty applications such as boat construction.

YellaWood® brand pressure treated products are treated with preservatives (the "Preservatives") and preservative methods and technologies of unrelated third parties. For details regarding the Preservatives, methods, and technologies used by Great Southern Wood Preserving, Incorporated, see www.yellowood.com/preservative or write us at P.O. Box 610, Abbeville, AL 36310. Ask dealer for warranty details.

For warranty or for important handling and other information concerning our products including the appropriate Safety Data Sheet (SDS), please visit us at www.yellowood.com/warranties or write us at P.O. Box 610, Abbeville, AL 36310. YellaWood® and the yellow tag are federally registered trademarks of Great Southern Wood Preserving, Incorporated.

Great Southern Wood Preserving, Incorporated makes no warranties expressed or implied as to the fitness for a particular purpose of this plan.

Big Green Egg Table

IMPORTANT INFORMATION

YellaWood®
Pressure Treated Pine

- Consult the end tag to determine which preservative or preservative system was used in the treatment of that particular product. YellaWood® brand products may be used in direct contact with aluminum building products when limited to code-compliant construction applications that provide proper water drainage and do not allow the wood to be exposed to standing water or water immersion.
- Use fasteners and other hardware that are in compliance with building codes for the intended use.
- Do not burn preserved wood.
- Wear a dust mask and goggles when cutting or sanding wood.
- Wear gloves when working with wood.
- Some preservative may migrate from the treated wood into soil/water or may dislodge from the treated wood surface upon contact with skin.
- Wash exposed skin areas thoroughly.
- All sawdust and construction debris should be cleaned up and disposed of after construction.
- Wash work clothes separately from other household clothing before reuse.
- Preserved wood should not be used where it may come into direct or indirect contact with drinking water, except for uses involving incidental contact such as fresh water docks and bridges.
- Do not use preserved wood under circumstances when the preservative may become a component of food, animal feed or beehives.
- Do not use preserved wood as mulch.
- Only preserved wood that is visibly clean and free of surface residue should be used. If the wood is to be used in an interior application and becomes wet during construction, it should be allowed to dry before being covered or enclosed.
- Mold growth can and does occur on the surface of many products, including untreated and treated wood, during prolonged surface exposure to excessive moisture conditions. To remove mold from the treated wood surface, wood should be allowed to dry. Typically, mild soap and water can be used to remove remaining surface mold. For more information visit www.epa.gov.
- Projects should be designed and installed in accordance with federal, state and local building codes and ordinances governing construction in your area, and in accordance with the National Design Specifications (NDS) and the Wood Handbook.

DISPOSAL RECOMMENDATIONS

Preserved wood may be disposed of in landfills or burned in commercial or industrial incinerators or boilers in accordance with federal, state and local regulations.